

FOR SALE

BUILDING & BUSINESS - PICTON

\$660,000



323-325 PICTON MAIN ST. E.

PROXIMITY

Toronto	-	213 KM (2.9 hrs)
Kingston	-	85.5 KM (1.1 hr)
Belleville	-	34.2 KM (30 min)
Ottawa	-	272 KM (3.1 hrs)
Montreal	-	393 KM (4.7 hrs)

PROPERTY DETAILS

Building Area:	+/-1048 sf
Zoning:	CC (Core Commercial)
Heating/Cooling:	Ductless, Electric, Heat Pump
Realty Taxes:	\$798.33 (2023)
PIN:	550610074

- Ground level restaurant, well established, family run business with solid profit margins and plenty of room for growth
- Upstairs is a two bedroom apartment on two levels, with a private entrance
- Excellent exposure, in the Heart of downtown Picton

ECHO
PERRY-CUMBERLAND
 Sales Representative

✉ echopc@rtcr.com
 📞 cell: 613-985-3246
 📞 613-384-1997 ex. 13

KOSTAS DOULAS
 Broker of Record

✉ kdoulas@rtcr.com
 📞 613-384-1997 ex. 17

Rogers & Trainor

Commercial Realty (2009) Inc.
 Brokerage

WWW.RTCR.COM

📍 20 Gore Street, Suite 102
 Kingston, Ontario K7L 2L1

FOR SALE

323-325 PICTON MAIN STREET



FLOOR PLANS

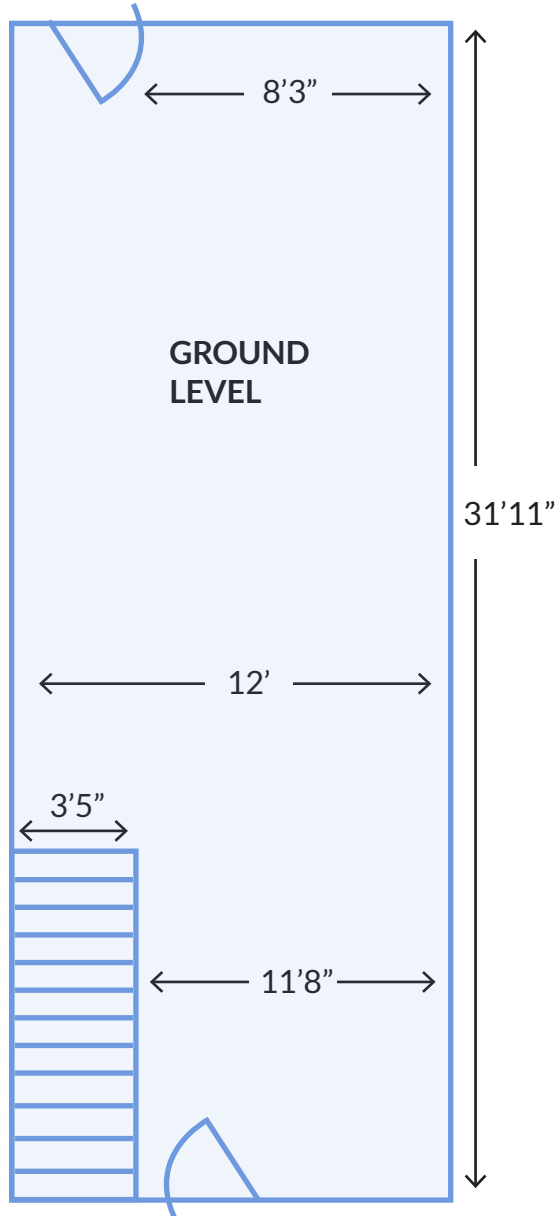

*Building is irregular, plans are not to scale

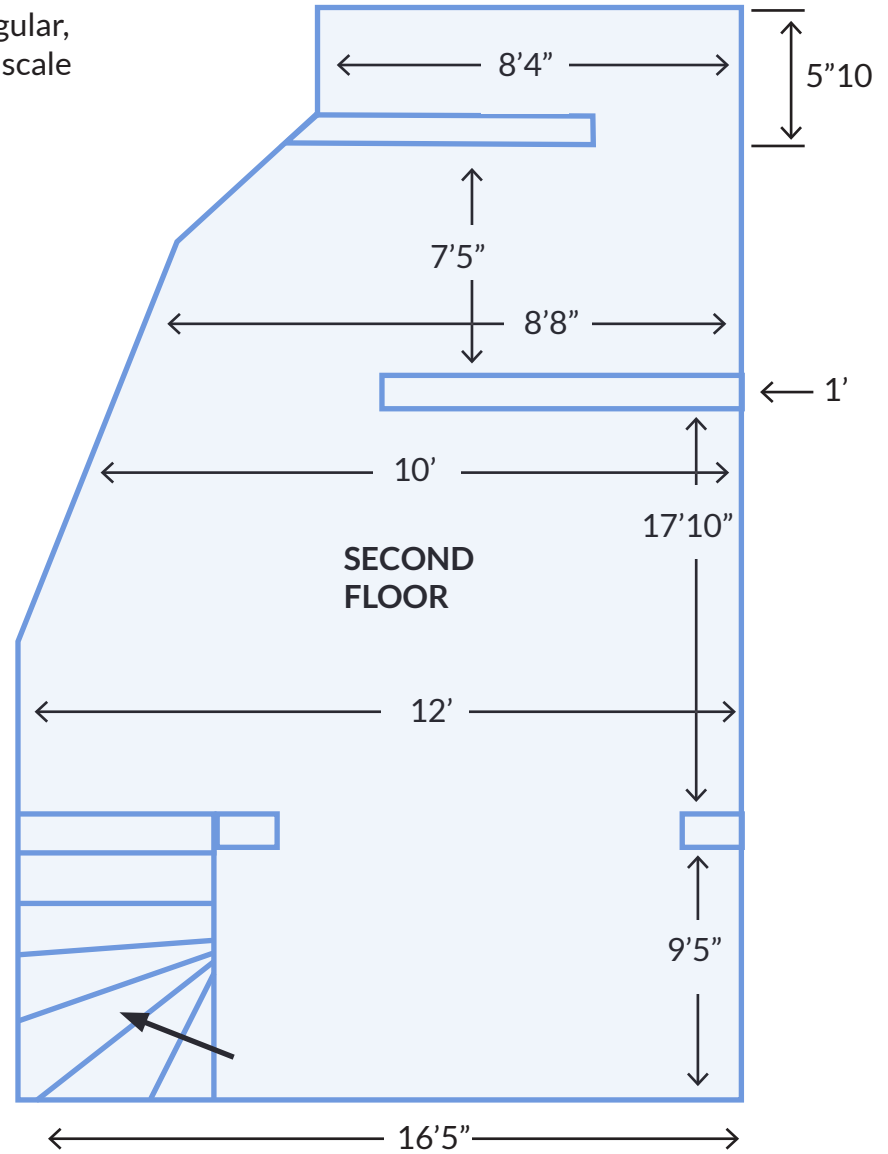

FLOOR PLANS

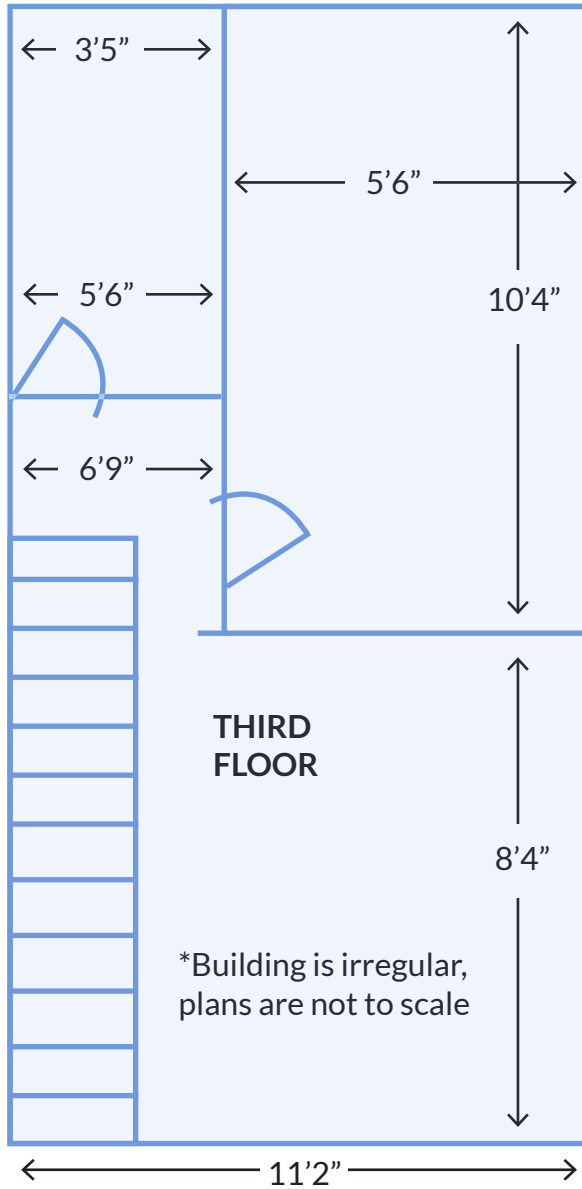

FOR SALE

323-325 PICTON MAIN STREET

PHOTOS



- Picton is located in Prince Edward County, roughly 160 km east of Toronto, and approximately 84 km west of Kingston
- Known for its architecturally significant buildings, and Main Street shops, Picton is a popular tourist destination
- Home to some of Ontario's most magical natural hotspots, like Lake on the Mountain and Sandbanks Provincial Park, Picton is home to attractions for all ages

NEIGHBOURHOOD HIGHLIGHTS

RESTAURANTS

- The Acoustic Grill
- Coaches Pub & Grillhouse
- Crepe Escape
- The Blue Sail Seafood
- Bocado
- Onesta

GROCERY

- Metro
- NoFrills
- Foodland
- Taste Your World
- Bulk Barn
- Giant Tiger
- Agrarian Market
- Penny's Pantry

FITNESS & RECREATION

- The Country Club and Spa Inc.
- Body Matrix Movement Studio PEC
- The Gym in the Armoury
- The Centre for Health & Fitness
- Sandbanks Provincial Park
- Dunes Beach
- Lighthall Vineyards
- Glenora Ferry
- Macaulay Heritage Park

AMENITIES

- Service Ontario
- The Beer Store, LCBO
- BMO, CIBC, RBC, Scotiabank, TD
- Dollarama
- Pet Valu
- Canada Post

